

ELECTRON BEAM IRRADIATED POLYAMIDE MEASURED BY INDENTATION HARDNESS

MARTIN OVSIK, MICHAL STANEK,
VACLAV JANOSTIK, MARTIN REZNICEK

Tomas Bata University in Zlin
Zlin, Czech Republic

DOI : 10.17973/MMSJ.2018_03_201730

e-mail : ovsik@ft.utb.cz

Cross-linking is a process in which polymer chains are associated through chemical bonds. Radiation, which penetrated through specimens and reacted with the cross-linking agent, gradually formed cross-linking (3D net), first in the surface layer and then in the total volume, which resulted in considerable changes in specimen behaviour. This research paper deals with the utilization of electron beam irradiated Polyamide 11 on the nano-indentation test. Radiation doses of 66, 132 and 198 kGy were used for unfilled PA with the 5% crosslinking agent (triallyl isocyanurate). The measurement results indicated that ionizing beta radiation was a very effective tool for improvement of indentation hardness, indentation modulus, indentation creep and deformation works of studied polymers. The best results were achieved by irradiation at doses of 132 kGy (increase about 31%) by which the highest nano-mechanical properties of PA11 were achieved.

KEYWORDS

polyamide, electron beam, cross-linking,
nano-hardness, indentation

1 INTRODUCTION

Polyamides are one of the most commonly used polymers. Due to their very high strength and durability polyamides are commonly used in textiles, carpets and floor coverings or automotive. Probably more familiar name designation is nylon. Polyamide 11 (PA11) is a semi-crystalline thermoplastic material with very high toughness, good chemical stability and impact resistance. PA11 is also a good electrical insulator and as other polyamide insulating properties will not be affected due to moisture. It is also resistant to corrosion. PA11 has many features and enhancements in terms of plasticization of improved varieties. Polyamide 11 is thanks to its very good mechanical properties, which can be even improved as shown in the results, suitable for applications with great demand on the stiffness and resistance of surface layers for instance friction parts used in automotive industry.

Polyamides are polymers whose repeating units are characterized by the amide group. Through radiation cross-linking, thermoplastic polyamides are turned into plastics which behave like elastomers over a wide temperature range. Cross-linking makes the originally thermoplastic product able to withstand considerably higher temperatures of up to 350 °C. The dimensional stability under thermal stress is also improved. Radiation cross-linked polyamide can often replace thermosetting plastics or high-performance plastics such as PPS, PEI, LCP, etc. One application that has proved most useful over the years is radiation cross-linked components for the

electrical industry, e.g. switch components, and the automotive industry, for instance components for the engine compartment.

Electron beams (β -rays) generated by accelerators are monoenergetic and the absorbed dose is greatest just below the surface of the irradiated material and falls rapidly at greater depths in the material (Fig. 1). The energy range of electron beams used in radiation processing is from 0.15 to 10 MeV. Compared with gamma irradiation, electron accelerators have advantages of higher power and directional beams. The time of irradiation by β -rays is in seconds. The limited penetrating power of electron beams means that they are mainly used for irradiating relatively thin objects like wires and cable insulation.

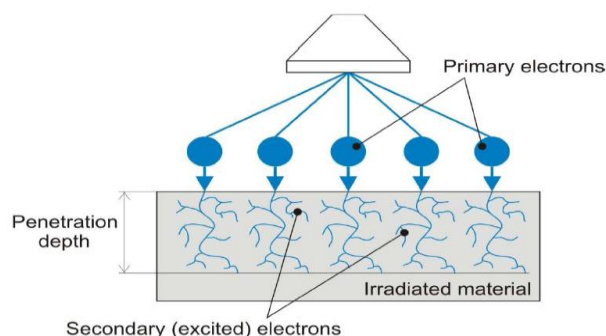

Figure 1. Radiation crosslinking by electrons rays

In general, copolymers cross-link more readily than polyamide. Common PA11, when exposed to the effect of the radiation cross-linking, degrades and its mechanical properties deteriorate. Mechanical properties of polyamides are modified by irradiation, as seen by reduced tensile strength (50% loss when irradiated in air, 16% under vacuum). Aromatic polyamides retain strength better than aliphatic polyamides. Using cross-linking agent TAIC (triallyl isocyanurate) produces a cross-linking reaction inside the PA11 structure. The utility properties of PA11 improve when the non-crystalline part of PA11 is cross-linked.

The aim of this paper is to study the effect of ionizing radiation with different doses, on nano-mechanical properties of polyamide 11 and compare these results with those of non-irradiated samples. The study is carried out due to the ever-growing employment of this type of polymer (polyamide 11).

2 EXPERIMENTAL

2.1 Material

For this experiment Polyamide 11 PA11 V-PTS-Creamid-11-AMN 0 TLD, that were supplied by PTS Plastics Technology Service, Germany was used. The material already contained the special cross-linking agent TAIC - triallyl isocyanurate (5 volume %), which should enable subsequent cross-linking by ionizing β - radiation.

2.2 Sample preparation

The samples were made using the injection molding technology on the injection molding machine Arburg Allrounder 470H. Processing temperature 240–260 °C, mold temperature 60 °C, injection pressure 90 MPa, injection rate 50 mm/s. It was used normalized specimen measuring 80x10x4 mm (Fig. 2).

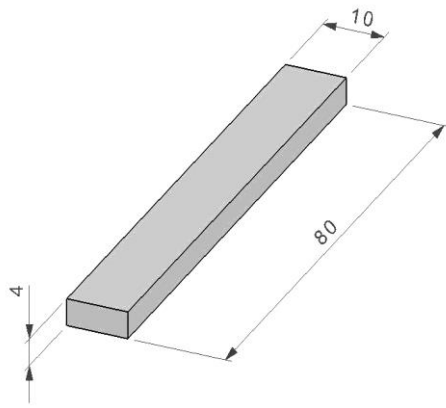

Figure 2. Dimension of sample

2.3 Irradiation

The prepared specimens were irradiated with doses of 0, 66, 132 and 198 kGy at BGS Beta-Gamma Service GmbH & Co. KG, Germany.

2.4 Nano-indentation test

Nano-indentation test were performed using a Nano-indentation tester (NHT), CSM Instruments (Switzerland) according to the CSN EN ISO 14577 (fig. 3). The tip is made of diamond having the shape of a cube corner (Vickers). In the present study, the maximum load used was 250 mN and loading rate (and unloading rate) was 500 mN/min. A holding time was 90 s at the indentation and 21600 s at the creep.



Figure 3. Nano-indentation tester

The indentation hardness H_{IT} was calculated as maximum load to the projected area of the hardness impression according to:

$$H_{IT} = \frac{F_{max}}{A_p} \quad (1)$$

$$E_{IT} = E^* \cdot (1 - \nu_s^2) \quad (2)$$

Where h_{max} is the indentation depth at F_{max} , h_c is contact depth. In this study the Oliver and Pharr method was used calculate the initial stiffness (S), contact depth (h_c). The specimens were glued on metallic sample holders (Fig. 4).

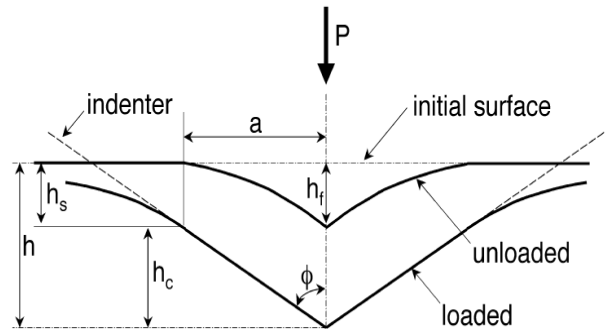

Figure 4. Schematic illustration of indentation curve

The indentation modulus is calculated from the Plane Strain modulus using an estimated sample Poisson's ratio:

$$E_{IT} = E^* \cdot (1 - \nu_s^2) \quad (3)$$

Determination of indentation hardness C_{IT} , where h_1 is the indentation depth at time t_1 of reaching the test force (which is kept constant), h_2 is the indentation depth at time t_2 of holding the constant test force:

$$C_{IT} = \frac{h_2 - h_1}{h_1} \cdot 100 \quad (4)$$

Measurement of all above mentioned properties was performed 10 times to ensure statistical correctness.

3 RESULTS AND DISCUSSION

Radiation cross-linking creates changes in the polyamide 11 structure by creating 3D net. Beta radiation gradually penetrates more deeply into the PA11 structure through the surface layer. The surface layer undergoes changes which have a considerable influence on the nano-mechanical properties of PA11.

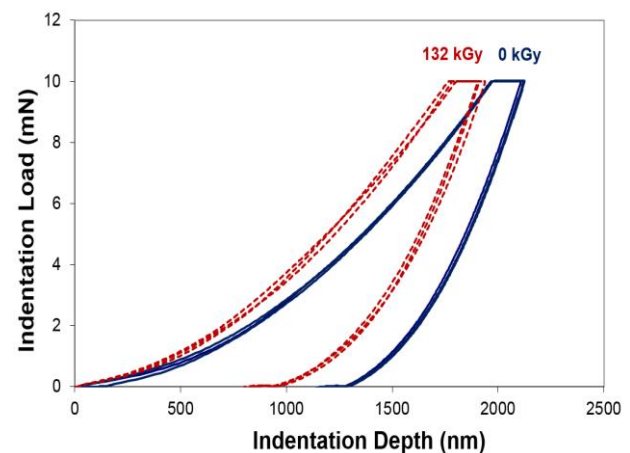

Figure 5. Indentation characteristic of irradiated PA11

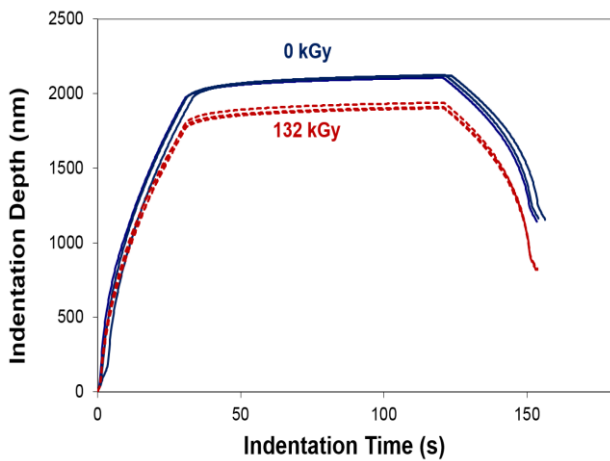

Figure 6. Indentation characteristic of irradiated PA11

The Fig. 5 and Fig. 6 shows a very important correlation between the force and the depth of the indentation. The correlations provide very valuable information on the behaviour of tested material and the modified surface layer. The correlation between the force and the depth of the indentation in PA11 also proved very interesting. It demonstrated the influence of radiation on the change of nano-mechanical properties in the surface layer of specimens. The non-irradiated material showed low hardness as well as increasing impression of the indenter in the surface layer. On the contrary, the irradiated PA11 showed considerably smaller depth of the impression of the indenter which can signify greater resistance of this layer to wear.

The values measured during the nano-hardness test showed that the lowest values of indentation hardness and Vickers hardness were found for the non-irradiated PA11 ($H_{IT} = 105.7$ MPa, HV = 10.7 Vickers). On the contrary, the highest values of indentation hardness and Vickers hardness were obtained for PA11 irradiated by a dose of 132 kGy ($H_{IT} = 138.8$ MPa, HV = 11.9 Vickers) (by 31% higher in comparison with the non-irradiated PA11), as can be seen at Fig. 7 and Fig. 8.

The greatest values of nano-hardness test were obtained for PA11 irradiated with dose of 132 kGy as is apparent in Table 1.

Irradiation doses	0kGy	66kGy	132kGy	198kGy
H_{IT} [MPa]	105,70	127,50	138,80	125,30
HV [Vickers]	10,70	11,80	11,90	11,60
E_{IT} [GPa]	1,80	1,90	2,00	1,90
Creep [%]	6,60	6,40	6,00	5,80
W_{el} [uJ]	0,38	0,38	0,40	0,39
W_{pl} [uJ]	0,66	0,63	0,63	0,65

Table 1. Summary of measured values

According to the results of measurements of nano-hardness, it was found that the highest values of indentation modulus of elasticity were achieved at the PA11 irradiated with dose of 132 kGy (by 11% higher than compared with non-irradiated PA11). On the contrary, the lowest values of the indentation modulus of elasticity were found for non-irradiated PA11, as is seen at Fig. 9.

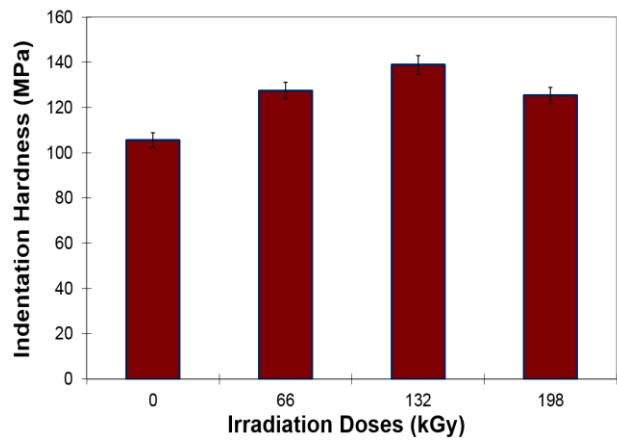

Figure 7. Indentation hardness (H_{IT})

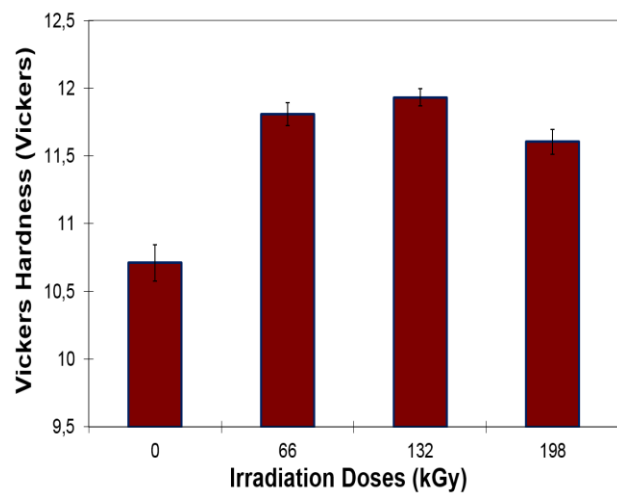

Figure 8. Vickers hardness (HV)

Very important values were found for indentation creep. Higher radiation dose influence significantly the indentation creep. An indentation creep increase of the surface layer is caused by irradiation cross-linking of the tested specimen. The lowest value of indentation creep was measured at radiation dose of 132 kGy. The highest indentation creep value measured at non-irradiated PA11. Decrease in creep values was 10% for irradiated PA11 compared to the non-irradiated one as is seen at Fig. 10.

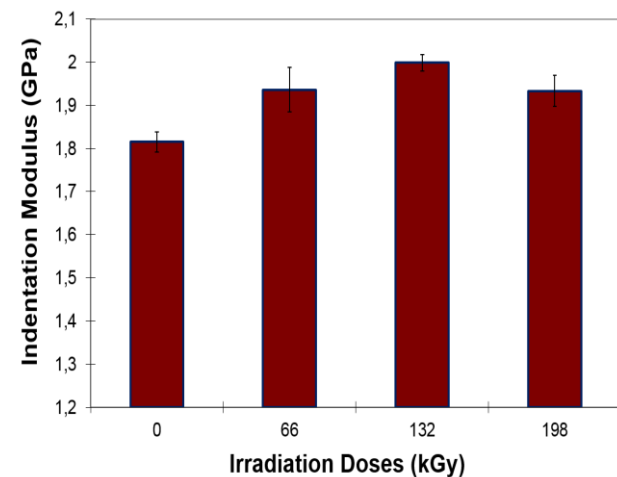

Figure 9. Indentation modulus (E_{IT})

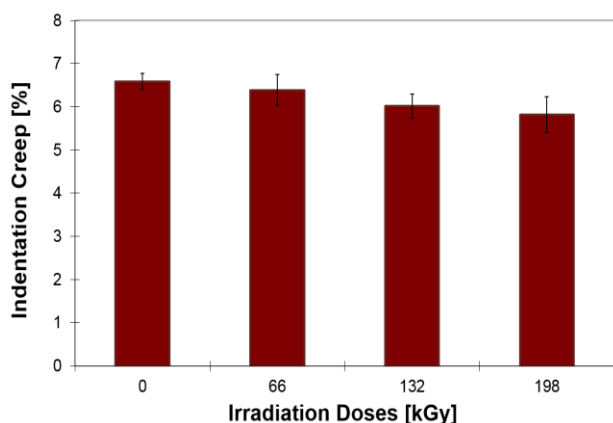

Figure 10. Indentation creep (C_{IT})

4 CONCLUSIONS

This research paper investigates influence of modified polymer material (beta radiation) on the nano-indentation test. The surface layer of PA11 is modified by β – radiation with doses of 66, 132 and 198 kGy.

Radiation, which penetrated through specimens and reacted with the cross-linking agent, gradually formed cross-linking (3D net), first in the surface layer and then in the total volume, which resulted in considerable changes in specimen behaviour.

Irradiation of PA11 with a β - radiation influences the nano-mechanical properties in the following way:

- Radiation of specimens caused improvement values of indentation hardness and indentation modulus.
- The highest values of indentation hardness and indentation modulus were achieved at the PA11 irradiated with dose of 132 kGy.
- Higher radiation dose does not influence the indentation hardness and indentation modulus significantly, on the contrary due to degradation processes the properties deteriorate.
- Values of indentation hardness and indentation modulus correspond to the deformation works.

Instrumented nano-hardness test of polyamide 11 beta irradiated samples was performed. After the beta radiation the amorphous part was cross linked what was accompanied with the radical increase of nano-hardness and indentation modulus of elasticity. The largest increase was observed in both cases using the doses of 132 kGy. The properties of surface layer of polyamide 11 were modified significantly by beta radiation improved. The nano-hardness values were increased by 31%. Stiffness of surface layer increased significantly by 11% as a result of radiation. The creep values of irradiated polyamide 11 decreased by 10% on average. The highest values of nano-mechanical properties were reached at radiation dose of 132 kGy. With higher radiation doses, the resulting values of nano-mechanical properties decreased and then showed constant values.

The results of nano-mechanical properties of surface layer of modified PA11 show that it can be used in more difficult applications in some industrial fields, in particular where there are high requirements for strength, stiffness and hardness of surface layer which appears to be the most suitable area of application.

ACKNOWLEDGMENTS

This paper is supported by the internal grant of TBU in Zlin No. IGA/FT/2017/010 funded from the resources of specific university research and by the Ministry of Education, Youth and Sports of the Czech Republic within the National Sustainability Programme project No. LO1303 (MSMT-7778/2014) and also by the European Regional Development Fund under the project CEBIA-Tech No. CZ.1.05/2.1.00/03.0089.

REFERENCES

- [Behalek 2013] Behalek, L. and Dobransky, J. Conformal cooling of the injection moulds. *Applied Mechanics and Materials*. Vol. 308 (2013). pp. 127-132. ISSN 1660-9336.
- [Drobny 2003] Drobny, J. G. *Radiation Technology for Polymers*, CRC Press, New York, (2003).
- [Dobransky 2013] Dobransky, J. et al. Comparison of Cooling Variants by Simulation Software. *Advanced Materials Research*. Vol. 801 (2013). pp. 75-80. ISSN 1022-6680.
- [Dobransky 2015] Dobransky, J. et al. Solving Depressions Formed During Production of Plastic Molding. *Metalurgija*. Vol. 54. No. 3 (2015). pp. 496-498. ISSN 0543-5846.
- [Manas 2015] Manas, D. et al. Effect of low doses beta irradiation on micromechanical properties of surface layer of injection molded polypropylene composite. *Radiation Physics and Chemistry*, (2015) 114, pp. 25-30.
- [Oliver 2004] Oliver, W. C. and Pharr, G. M. Measurement of Hardness and Elastic Modulus by Instrumented Indentation. *Journal of Materials Research* 19 (1), (2004), 1564 – 1583.
- [Ovsik 2012] Ovsik, M. et al. Irradiated Polypropylene Studied by Microhardness and WAXS, *Chemicke listy*, 106 (2012), 507-510.
- [Ovsik 2015] Ovsik, M. et al. Micro-indentation test and morphology of electron beam irradiated HDPE. *Key Engineering Materials*, 662, (2015), pp. 189-192.
- [Pharr 1998] Pharr, G. M. Measurement of mechanical properties by ultra-low load indentation. *Materials Science and Engineering* (1998).

CONTACTS:

Ing. Martin Ovsik, Ph.D.
 Ing. Michal Stanek, Ph.D.
 Ing. Vaclav Janostik
 Ing. Martin Reznicek, Ph.D.

Tomas Bata University in Zlin,
 TGM 5555, 760 01 Zlin, Czech Republic
 Tel.: +420 576 035 100

ovsik@ft.utb.cz
stanek@ft.utb.cz
janostik@ft.utb.cz
mreznicek@ft.utb.cz